

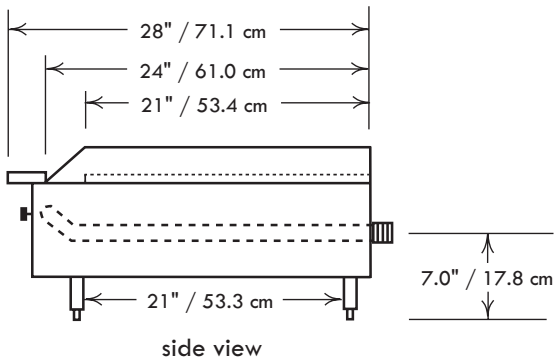

JOB _____ ITEM # _____

GRIDDLES

FHP Series, 21" Cook Depth

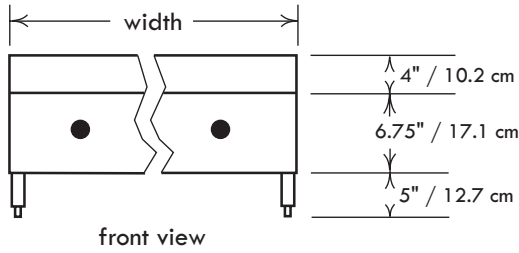

Standard Features, Benefits & Options

CONSTRUCTION: Easy cleaning, corrosion resistant stainless steel finish, welded with angle iron and aluminized inner framing. Sturdy 5" heavy duty stainless pipe legs with adjustable feet. 4" wide stainless steel bull nose landing across the front is a functional work area for service plates and work utensils as well as control protection. Double wall construction with heavy insulation for cooler operation. Installation clearances for non-combustible surfaces are 0" on the sides and 0" in the rear, combustible surfaces are 4" on the sides and 5" in the rear.

GRIDDLE PLATE: Highly polished to minimize food sticking. 3/4" thick plate is standard, 1" thick is available. 4" high splash guard is standard. Higher sides are also available. 21 1/4" deep cooking surface with front, cold zone grease trough. Grease drain slot is 3.5" x 1" and feeds into a seamless, deep, removable grease drawer.

CONTROLS: Equipped with brass gas valves and automatic standing pilots. Pressure regulators are set at the factory for the gas specified. Optimal pressures are 4" WC for natural gas and 10" WC for propane. Manifold size is 3/4" NPT. All controls are tested and confirmed in good working order. Calibration and adjustments are the responsibility of the installer.

BURNERS: 12" incremental griddles feature 20,000 BTU cast iron "H" pattern burners, one for each 12" increment. 18" & 30" models feature 2 and 4 straight burners respectively, each rated at 18,000 BTU.

MATCH-UP: FHP Series griddles are designed to match up with FHP char-broilers and hot plates.

ACCESSORIES & OPTIONS: Thermostats, 1" thick plates, chrome plating, grooved surfaces, safety pilot controls, gas hoses, grill scrapers, spatulas, cleaning supplies, carrying handles, knob protectors and matching equipment stands.

SPECIFICATIONS

Model Number	Width in./mm.	# of Thermostats	Total BTU	Approx. kg/lbs
FHP12-12	12 / 305	0	20K	52 / 115
FHP18-18	18 / 457	0	36K	73 / 160
FHP18-18T	18 / 457	1	36K	75 / 165
FHP24-24	24 / 610	0	40K	93 / 205
FHP24-24T	24 / 610	2	40K	95 / 210
FHP30-30	30 / 762	0	72K	125 / 275
FHP30-30T	30 / 762	2	72K	127 / 280
FHP36-36	36 / 914	0	60K	130 / 285
FHP36-36T	36 / 914	3	60K	132 / 290
FHP42-42	42 / 1067	0	108K	143 / 315
FHP42-42T	42 / 1067	3	108K	145 / 320
FHP48-48	48 / 1219	0	80K	161 / 355
FHP48-48T	48 / 1219	4	80K	166 / 365
FHP54-54	54 / 1372	0	144K	182 / 400
FHP54-54T	54 / 1372	6	144K	191 / 420
FHP60-60	60 / 1524	0	100K	211 / 465
FHP60-60T	60 / 1524	5	100K	211 / 465
FHP72-72	72 / 1829	0	120K	273 / 600
FHP72-72T	72 / 1829	6	120K	273 / 600

Thermostat & manual control specific spec sheets available online or call factory.

NOTICE: In an ongoing effort of product development & improvement, Comstock-Castle reserves the right to change specifications and product design without notice. Such modifications do not entitle the buyer to corresponding changes or replacements for previously purchased equipment.



Comstock-Castle Stove Co. • 119 W. Washington St. • Quincy, IL. 62301
Tel.: 217-223-5070 • Fax: 217-223-0007 • www.castlestove.com

