

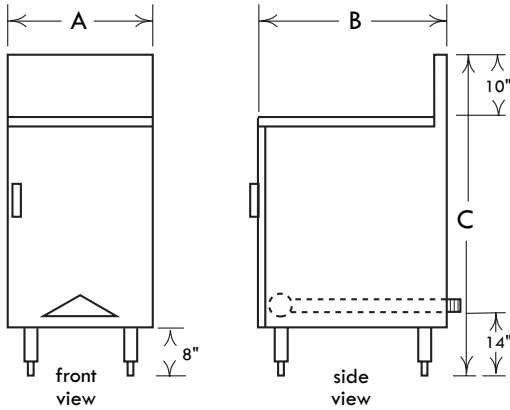

America's Oldest Stove Company  
(Est. 1838)

JOB \_\_\_\_\_ ITEM # \_\_\_\_\_

# HIGH VOLUME TUBE FRYERS



## Standard Features & Benefits

**CONSTRUCTION:** Easy cleaning, corrosion resistant stainless steel finish, welded with aluminized inner framing. Triple flue design for cooler and more efficient operation. Adjustable 6" stainless steel legs for easy leveling. Installation clearances for non-combustible surfaces are 2" on sides and 6" in the rear, combustible surface clearances are 6" and 6". Hinged front door panel protects controls.

**CONTROLS:** Snap Action thermostat for fast recovery, 100% safety shut off with built in pressure regulator, high limit control for back-up safety, automatic standing pilot and brass burner valves. Optimal pressures are 4" WC for natural gas and 10" WC for propane. Manifold size is 3/4" NPT. All controls are tested and confirmed in good working order. Calibration and adjustments are the responsibility of the installer.

**TANK:** Easy cleaning, corrosion resistant stainless steel tube type tank for maximum surface heat transfer. Stainless steel tube radiant inserts for increased efficiency and rapid recovery. Deep cold zone allows food particles to sink below tubes reducing shortening breakdown and taste transfer as well as extending the life and quality of fryer shortening. 1" gate valve for rapid draining.

**BASKETS:** Two heavy duty, nickel plated wire baskets. Permanently affixed hanger rack firmly suspends loaded baskets out of frying vat.

**ACCESSORIES:** Single large baskets, stainless steel tank covers, gas hoses, cleaning supplies, equipment stands and casters are listed in the price list.

SPECIFICATIONS				
Model		10HF	14HF/14HC	18HF
Width "A"	in.	11	15/15	19
	cm	27.9	38.1/38.1	48.3
Depth "B"	in.	21.75	26/26	30
	cm	55.2	66/66	48.3
Height "C"	in.	40	43.5/27.5	46
	cm	101.6	110.5/69.9	116.8
Approx. Ship Weight	lbs.	125	170	255
	kgs	56.7	78	116
Total	BTU	60,000	90,000	120,000
TANK INTERIOR				
Width	in.	10	14	18
Height (to tube)	in.	8	8	9.875
Length	in.	15.875	18	22.75
FRYER TANK FILL CHART GUIDE				
Gallons		3.5 & up to 4	6	10 (min.) & up to 12
Liters		13/15	23	38/45
Pounds		27/31	40	70
Kilograms		12/14	21	35/42

[Based on Soybean Oil with a specific gravity of 0.927 at 15°C (59°F).]

*This chart is intended to be a guide. Adjustments may be made to accommodate the cooking demands of various establishments.*



Comstock-Castle Stove Co. • 119 W. Washington • Quincy, IL 62301 USA  
Tel.: 217-223-5070 • Telefax: 217-223-0007 • www.castlestove.com

